

Pt100 converter, loop-powered

3333

- High accuracy, better than 0.1% of span
- Slimline housing of 6 mm
- Excellent EMC performance and 50/60 Hz noise suppression
- Selectable < 30 ms / 300 ms response time
- Pre-calibrated temperature ranges selectable via DIP-switches



Application

- The 3333 temperature converter measures a standard 2-, 3- or 4-wire Pt100 temperature sensor, and provides a passive analog current output signal.
- The 3333 can be mounted in the safe area or in Zone 2 / Division 2 areas.
- Approved for marine applications.

Technical characteristics

- Flexibly loop powered by 3.3...35 VDC via connectors.
- < 30 ms fast response time with simultaneous sensor error detection when selected.
- Selectable 300 ms response time when signal dampening is needed.
- High conversion accuracy in all available ranges, better than 0.1% of span.
- Meeting the NAMUR NE21 recommendations, the 3333 provides top measurement performance in harsh EMC environments.
- The device meets the NAMUR NE43 standard defining out of range and sensor error output values.
- All terminals are protected against overvoltage and polarity error.
- Excellent signal/noise ratio of > 60 dB.

Mounting / installation / programming

- Selectable DIP-settings for easy configuration of more than 1000 factory calibrated measurement ranges.
- The narrow 6 mm housing allows up to 165 units to be mounted per meter of DIN rail, without any air gap between units.
- Wide ambient temperature range of -25...+70°C.

Connections

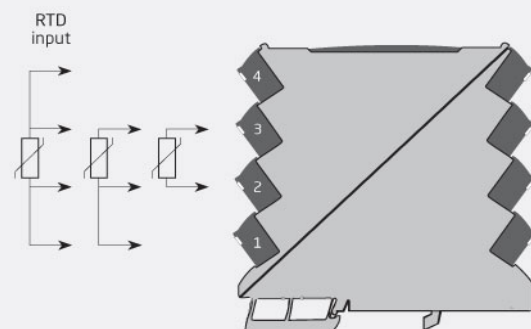

*Safe Area or
Zone 2 & Cl. 1, Div. 2, gr. A-D*

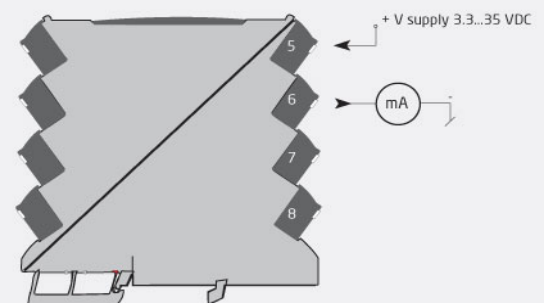

Order:

Type
3333

Environmental Conditions

Specifications range.....	-25°C to +70°C
Storage temperature.....	-40°C to +85°C
Calibration temperature.....	20...28°C
Relative humidity.....	< 95% RH (non-cond.)
Protection degree.....	IP20
Installation in.....	Pollution degree 2 & measurement / overvoltage cat. II

Mechanical specifications

Dimensions (HxWxD).....	113 x 6.1 x 115 mm
Weight approx.....	70 g
DIN rail type.....	DIN EN 60715/35 mm
Wire size.....	0.13 x 2.5 mm ² / AWG 26...12 stranded wire
Screw terminal torque.....	0.5 Nm
Vibration.....	IEC 60068-2-6 : 2007
Vibration: 2...25 Hz.....	±1.6 mm
Vibration: 25...100 Hz.....	±4 g

Common specifications

Supply voltage.....	3.3...35 VDC
Voltage drop.....	3.3 VDC
Signal / noise ratio.....	> 60 dB
Signal dynamics, input.....	23 bit
Signal dynamics, output.....	18 bit
Response time (0...90%, 100...10%).....	< 30 ms / 300 ms (selectable)
EMC immunity influence.....	< ±0.5% of span
Extended EMC immunity: NAMUR NE 21, A criterion, burst.....	< ±1% of span
Incorrect DIP-switch setting identification.....	3.5 mA

Input specifications

Temperature range, Pt100.....	-200...+850°C
Accuracy, RTD: the greater of.....	Better than 0.1% of span or 0.2°C
Temperature coefficient, RTD: the greater of.....	0.02°C/°C or ≤ ±0.01%/°C
Sensor current, RTD.....	< 150 µA
Sensor cable resistance, RTD.....	< 50 Ω per wire
Effect of sensor cable resistance (3-/4-wire), RTD.....	< 0.002 Ω / Ω
Sensor error detection, RTD.....	Yes - selectable via DIP-switch
Broken sensor detection.....	> 800 Ω
Shorted sensor detection.....	< 18 Ω

Output specifications

Programmable current ranges.....	4...20 and 20...4 mA
Range limits.....	3.8...20.5 mA NAMUR NE43
Sensor error indication.....	3.5 mA or 23 mA / acc. to NAMUR NE43 or OFF
Load resistance, current output.....	≤ (Vsupply - 3.3) / 0.023 [Ω]
Updating time.....	10 ms
Load stability, current output.....	≤0.01% of span / 100 Ω

Approvals

EMC.....	EN 61326-1
LVD 2006/95/EC.....	EN 61010-1
ATEX 2004/108/EC.....	KEMA 10ATEX0147 X
IECEx.....	KEM 10.0068X
FM.....	3041043-C
DNV Marine.....	Stand. f. Certific. No. 2.4
GL.....	V1-7-2
EAC TR-CU 020/2011.....	EN 61326-1
UL.....	UL 61010-1